

Heat Exchanger **HE SERIES**

EXCELLENT HEAT TRANSFER CAPABILITY

Connects to different kinds of boilers, heat pumps and solar panel systems



Product Features

1. High quality acid-resistant AISI-316 stainless steel
2. Precision-welded outer jacket
3. Seamless pipes equipped with flow restrictors for high heat exchange capacity
4. Four size: 40, 60, 75, 120 kW, suitable for swimming pools of up to 450m³



Product Information



1. PP Baffle stick
2. SS AISI-316 stainless steel casing (Ø133x1.5mm)
3. SS AISI-316 stainless steel heat transfer tubes (Ø10x0.6mm)
4. SS AISI-316 stainless steel base

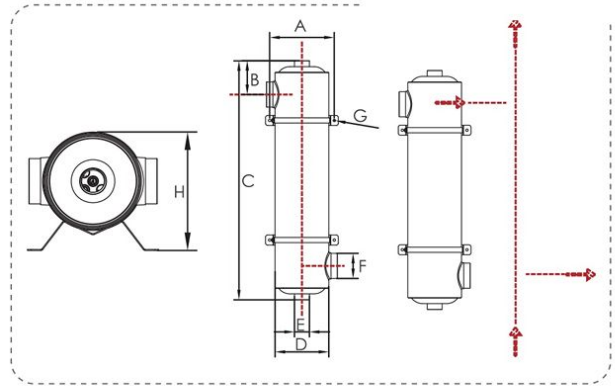

Product Dimensions

Code	Model	A mm	B mm	C mm	D mm	E mm	F mm	G mm	H mm
88540101	HE40	160	75	360	Ø133	1"	1.5"	Ø6	165mm
88540102	HE60	160	75	480	Ø133	1"	1.5"	Ø6	165mm
88540103	HE75	160	85	600	Ø133	1"	2"	Ø6	165mm
88540104	HE120	160	85	1070	Ø133	1.5"	2"	Ø6	165mm

Technical Data

Code	Model	Capacity		Weight kg	Hot Water Flow (l/min)	Pool Water Flow (l/min)
		kw	kBtu/h			
88540101	HE40	40	135	4.0	25	200
88540102	HE60	60	200	5.2	30	250
88540103	HE75	75	260	6.4	35	300
88540104	HE120	120	400	10.9	50	360

Testing Pressure

Pool Water Circuit: 10 Bar
Hot Water Circuit: 5 Bar

Installation

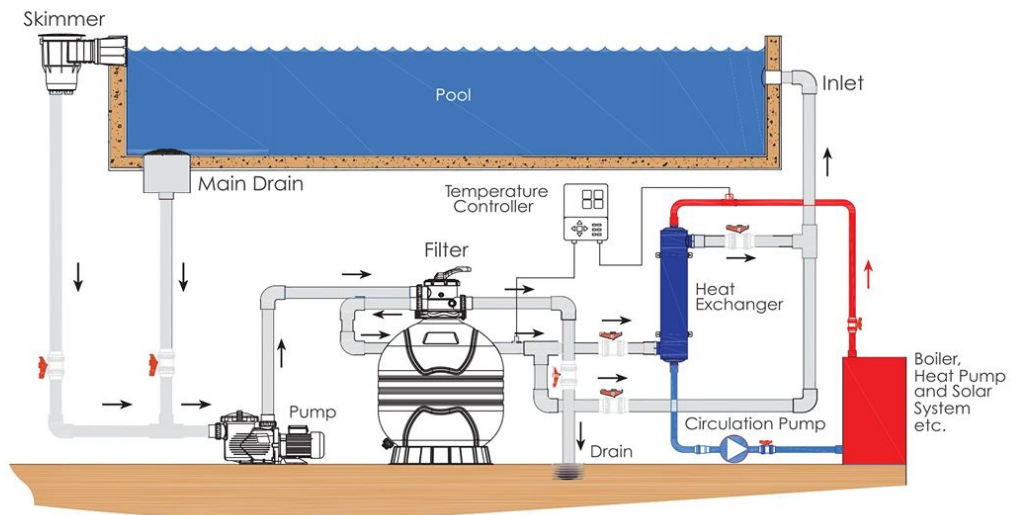

EMAUX WATER TECHNOLOGY CO., LTD

ADDRESS: Flat A-D, 20/F., Kai Bo 22, 22 Wing Kin Road, Kwai Chung, HK

PHONE +852 2832 9880

www.emauxgroup.com

Pool & Spa Equipment

YOUR PREMIER SUPPLIER

Available from:

ALL SPECIFICATIONS ARE SUBJECT TO CHANGE WITHOUT NOTICE
© 2021 EMAUX WATER TECHNOLOGY CO., LTD. ALL RIGHTS RESERVED.